

DIMENSION CHART

LATE 20'S ROADSTER (FORD)

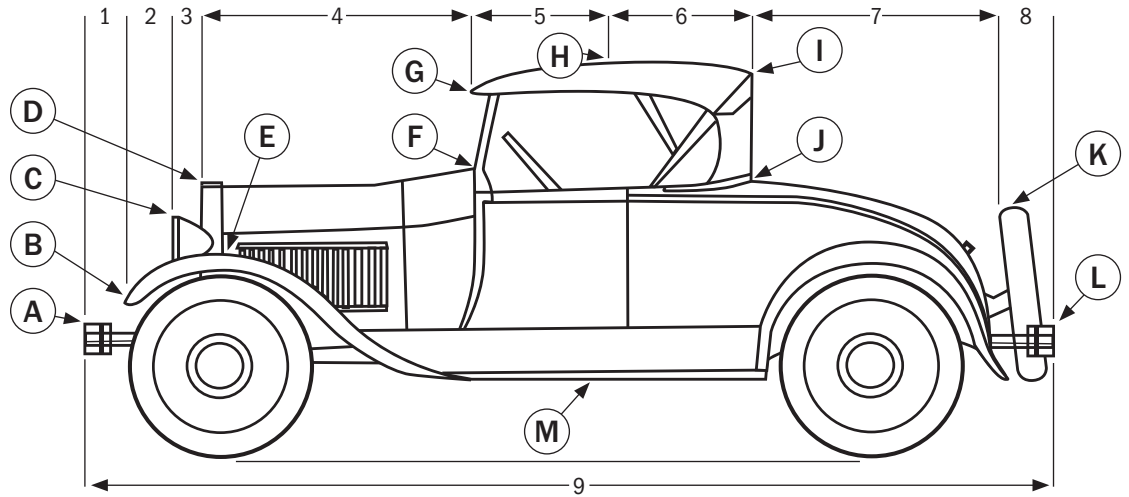

Lengths - Measured Horizontally Heights - Measured from Ground

<p>#1 Front of car to tip of fender _____</p> <p>#2 Tip of fender to front of headlights _____</p> <p>#3 Front of headlights to front of hood _____</p> <p>#4 Front of hood to front of roof _____</p> <p>#5 Front of roof to highpoint of roof _____</p> <p>#6 Highpoint of roof to rear of roof _____</p> <p>#7 Rear of roof to rear of fender _____</p> <p>#8 Rear of fender to rear of bumper _____</p> <p>(If measured correctly, #1 through #8 should equal #9)</p> <p>#9 Overall length of car, front to rear _____</p>	<p>Total _____</p>	<p>HA Height at "A" _____</p> <p>HB Height at "B" _____</p> <p>HC Height at "C" _____</p> <p>HD Height at "D" _____</p> <p>HE Height at "E" _____</p> <p>HF Height at "F" _____</p> <p>HG Height at "G" _____</p> <p>HH Height at "H" _____</p> <p>HI Height at "I" _____</p> <p>HJ Height at "J" _____</p> <p>HK Height at "K" _____</p> <p>HL Height at "L" _____</p> <p>HM Road Clearance _____</p>
--------------------------------------------------------------------------------------------------------------------------------------------------------------------------------------------------------------------------------------------------------------------------------------------------------------------------------------------------------------------------------------------------------------------------------------------------------------------------------------------------------------------------------	--------------------	--------------------------------------------------------------------------------------------------------------------------------------------------------------------------------------------------------------------------------------------------------------------------------------------------------------------------------------------------------------------------------------------------------

Widths, Measured Side to Side at Points Shown

<p>WA Width across front of car at "A" _____</p> <p>WB Width across fenders at "B" _____</p> <p>WC Width across headlights at "C" _____</p> <p>WD Width across hood at "D" _____</p> <p>WE Width, side to side at "E" _____</p> <p>WF Width at base of windshield _____</p>	<p>WG Width across front of roof _____</p> <p>WH Width across highpoint of roof _____</p> <p>WI Width across rear of roof _____</p> <p>WJ Width across body at "J" _____</p> <p>WK Width across car at "K" _____</p> <p>WL Width at rear bumper _____</p>
-----------------------------------------------------------------------------------------------------------------------------------------------------------------------------------------------------------------------------------------------------------------------------	-----------------------------------------------------------------------------------------------------------------------------------------------------------------------------------------------------------------------------------------------------------

Vehicle Information

YEAR _____

MAKE _____

MODEL _____

BODY STYLE _____

Date of Order _____

A photo of the vehicle will help us make the pattern.
The photo will be returned if requested.

Name _____

Daytime phone _____

Email _____